



High power even at low flow temperatures.
Ideal for use in:

- Offices
- Retail
- Residential
- Sustainability projects

Features Dynamic Boost Effect (DBE) technology for even greater power, **efficiency and control**. DBE allows the Mini Dynamic Canal to operate efficiently even at low flow temperatures. Whisper quiet even at the highest outputs



A wide range of grille options, from wood finishes to **designer styles**

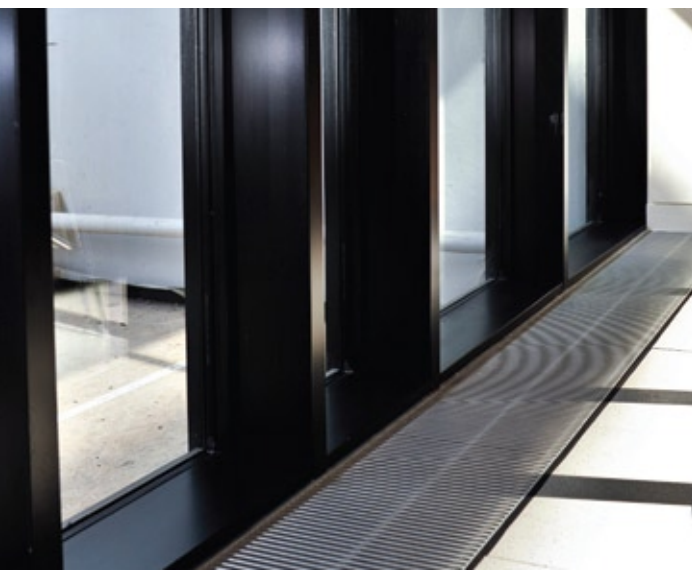

Increases design possibilities - one of the few fan assisted trench heating systems available in **curved lengths**

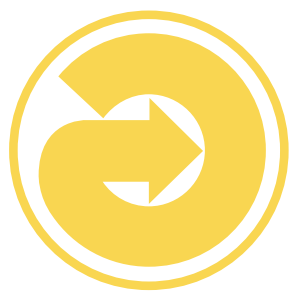

jaga

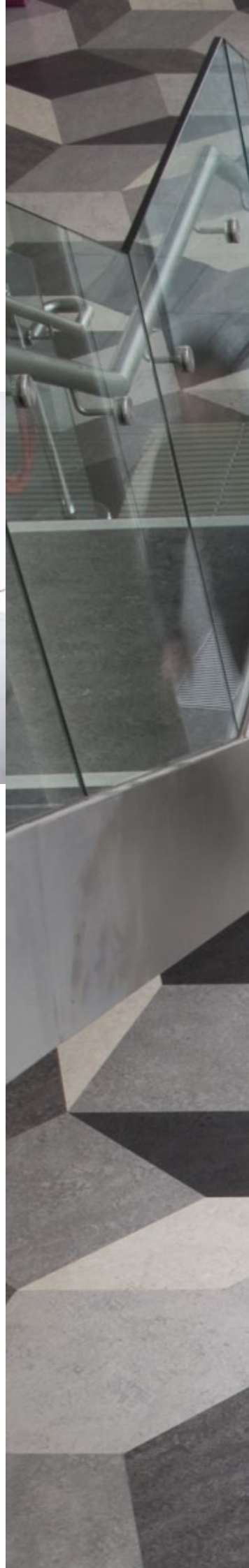



MINI DYNAMIC CANAL

low temperature heating systems

Mini Dynamic Canal

Outputs

Outputs in watts at 75/65/20°C, calculated in accordance with EN442



Depth ▼	Width ▼	Length ▶										
		1100	1300	1500	1700	1900	2100	2300	2500	2700	2900	3100
140	260	1085	1171	1626	2083	2169	2625	2711	3167	3254	3709	4166
	340	1410	1527	2115	2702	2820	3407	3525	4112	4229	4817	5404
	420	1793	1952	2690	3428	3587	4325	4483	5222	5380	6118	6857

All dimensions in millimetres.

Acoustic Data

Sound pressure and correction factors

Sound pressure per dynamic fan module equals 29db(A) internal sound

Several appliances with an equal sound level in a room

Number db(A)	Correction db(A)	
2	+3.0	$P2 = P1 + 10 \log n$ P1 = sound level one appliance P2 = sound level to be calculated n = number of appliances
3	+4.8	

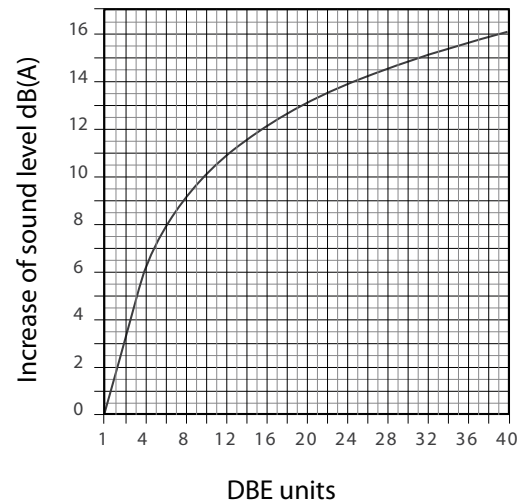

Correction Factor Equations

Equation to determine the mean water temperature difference, minus ambient air (ΔT)

Equation to determine water mass flow rate (m)

T_F = Water flow temperature °C
 T_R = Water flow return temperature °C
 amb = Ambient temperature °C

Q = Total heat emitted by unit (kW)
 m = Water mass flow rate (kg/s)
 C_p = Specific heat capacity (4.187 kJ/kg °C) Approximate

$$\text{Equation 1: } \Delta T = \frac{T_F + T_R}{2} - \text{amb}$$

$$\text{Equation 2: } m = \frac{Q}{(T_F - T_R) \times C_p}$$

As this is a dynamic product, outputs are not affected by grille finish

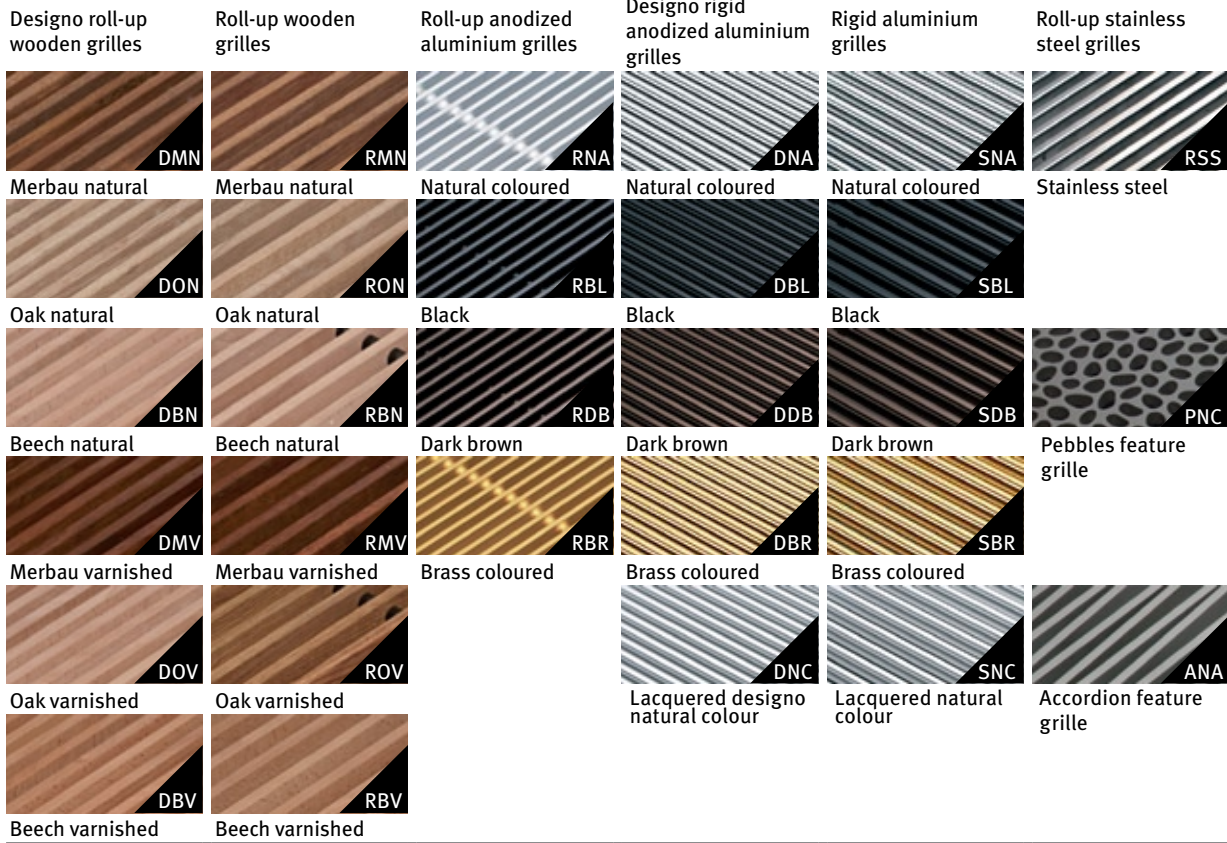

3 letter grille codes adjacent to grille images are required for ordering purposes.

Correction Factors

Outputs at 75/65/20°C, average correction factors calculated in accordance with EN442



T _F ▼	T _L ▼	T _R ▶	30	35	40	45	50	55	60	65	70
80	20		0.70	0.75	0.80	0.85	0.90	0.95	1.00	1.05	1.10
	24		0.62	0.67	0.72	0.77	0.82	0.87	0.92	0.97	1.02
75	20		0.65	0.70	0.75	0.80	0.85	0.90	0.95	1.00	1.05
	24		0.57	0.62	0.67	0.72	0.77	0.82	0.87	0.92	0.95
70	20		0.60	0.65	0.70	0.75	0.80	0.85	0.90	0.95	
	24		0.52	0.57	0.62	0.67	0.72	0.77	0.82	0.87	
65	20		0.55	0.60	0.65	0.70	0.75	0.80	0.85		
	24		0.47	0.52	0.57	0.62	0.67	0.72	0.77		
60	20		0.50	0.55	0.60	0.65	0.70	0.75			
	24		0.42	0.47	0.52	0.57	0.62	0.67			
55	20		0.45	0.50	0.55	0.60	0.65				
	24		0.37	0.42	0.47	0.52	0.57				
50	20		0.40	0.45	0.50	0.55					
	24		0.32	0.37	0.42	0.47					
45	20		0.35	0.40	0.45						
	24		0.27	0.32	0.37						
40	20		0.30	0.35							
	24		0.22	0.27							

KEY
 T_F = Flow temperature °C
 T_R = Return temperature °C
 T_L = Desired air temperature °C

The indicated outputs ΔT 50 °C are the exact outputs and are calculated in accordance with EN 442. An average correction factor is given in this table for outputs at other ΔT and is applicable for all dimensions. For comprehensive correction factors table see page 83.

Mini Dynamic Canal

Grille

A wide range of design types and colours in anodized aluminium, various wood finishes and stainless steel

Electrical connection

Take 12 volt DC supply

Protection grille

Low-H₂O heat exchanger

Made from copper and aluminium, made "invisible" by a dark grey lacquer RAL 7024

Thermal activator fan units

Mini duct

From Sendzimir galvanized and dark grey lacquered steel plate; thickness 1mm, with connection holes on all sides.

Seals

For the connection holes, made of black synthetic material. Hydraulic connection always on the left hand side (Connection on the right hand side on request).

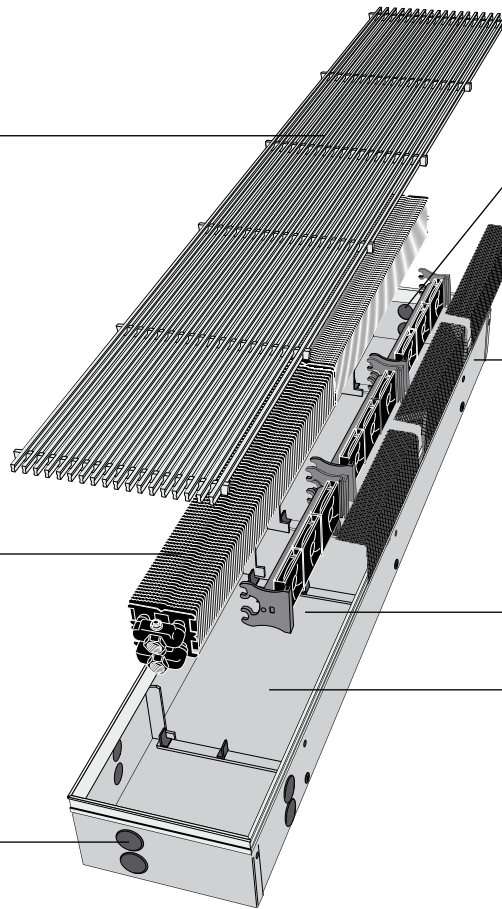

Installation

Options

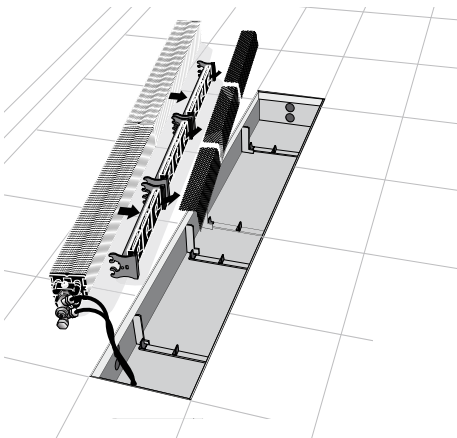

Flexible connections for fast assembly. Makes the Low-H₂O heat exchanger removable for maintenance.

Operating principle

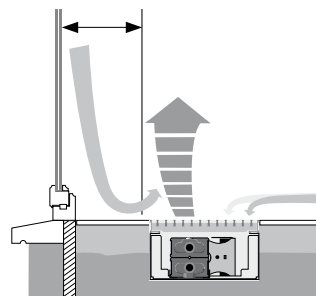

Sufficient space for curtains should be allowed.

Duct:

Shall be pre-mounted duct in Sendzimir galvanized steel plate of 1mm thick, complete with intermediate support brackets. This will be provided with anthracite grey epoxy polyester finish, RAL 7024 - gloss degree 10%. Specified lengths will comprise of suitable unitary lengths of up to 3100mm. Where longer lengths are required, separate units will be joined to form continuous lengths to suit site requirements.

The Duct is to be complete with 6No. pre-perforated holes for pipework accommodation, which are to be covered with black blanking plugs.

The duct is to be of sufficient quality to be provided with the manufacturer's 10 year guarantee.

Heat Exchanger:

Shall be manufactured from seamless copper tubes, fitted with aluminium fins. The fins shall provide high contact area to the tubes, guaranteeing optimum efficiency across a wide range of flow & return water temperatures. The heat exchanger shall be complete with 2No. Brass 1/2" BSP connections. Generally these shall be same end connections, and be suitable for left hand installation. The complete heat exchanger assembly shall be non corrosive and the whole assembly shall be electro statically lacquered with dirt repellent and dust proof anthracite grey epoxy polyester lacquer RAL 7024- gloss degree 70%.

The heat exchanger shall be supplied complete with 1/8" BSP air vent & 1/2" BSP drain cock, and the whole assembly to be pressure tested to 20 bar, with a maximum working pressure of 10 bar.

The element shall be of sufficient quality to be provided with the manufacturer's 30 year guarantee.

Frame:

The frame shall be constructed from reinforced L-profile, anodized aluminium, with a height of 31.5mm and a width of 24mm.

The frame shall be pre mounted on the mini floor duct, but will be removable to avoid deformation during installation or floor construction.

The frame shall be supplied to the specified finish and colour.

Where a lacquered colour is specified, it shall be lacquered in a scratch resistant epoxy- polyester powder, sprayed electro statically, and baked to 200°C. The colour shall be UV resistant due to ASTM G53. And the frame shall be of sufficient quality to be provided with the manufacturer's 10 year guarantee.

Fan Unit:

The unit shall be complete with one or more fan activator sections. The sections shall be powered by a 12 volt DC supply via a dedicated 240 volt power supply. Multiple units shall be connected to the low voltage supply with suitable connecting cables.

Control of the fan activators shall be on/off control by means of a microprocessor circuit board fixed to the heat exchanger. The circuit board shall be complete with a range of user definable temperature set points together with a surface contact temperature sensor to provide low water temperature hold off control of the fan. The processor shall also have the facility to be connected to a computer with dedicated software to enable adjustments of the standard parameters by the user.

Grilles:

Grilles shall be of the specified material and finish and to the relevant specification as follows:

Rigid Aluminium Grille:

Shall be constructed from anodized aluminium profiled slats placed lengthways (5 x 16mm), with 15mm space between. The slats shall be mechanically connected with two crossways supporting slats (5 x 27mm), with maximum 30.5mm space between, and be so constructed as to have a free air flow of not less than 75%.

Designo Rigid Aluminium Grille:

Shall be constructed from anodized aluminium slats placed lengthways (5 x 16mm), with 8.5 mm space between. The slats shall be mechanically connected with crossways supporting slats (5 x 27mm), with maximum 30.5mm space between, and be so constructed to have a free air flow of not less than 62.5%.

Roll-up Aluminium Grille:

Shall be constructed from anodized aluminium profiled slats placed crossways (5 x 23mm), with 11mm space between. The slats shall be interconnected by a galvanized steel spring, and fixed at the correct distance by aluminium pieces in the same colour, and be so constructed as to have a free air flow of not less than 70%.

Roll-up Stainless Steel Grille:

Shall be constructed from V2A 1.4301 stainless steel profiled slats placed crossways (8 x 18mm), with 12mm space between. The slats shall be interconnected by a metal spring, with a light grey synthetic coating, and be so constructed as to have a free air flow of not less than 60%.

Roll-up Designo Wooden Grille:

Shall be constructed from wooden profiled slats placed crossways (12 x 24.5mm), with 13mm space between. The slats shall be interconnected by a galvanized steel spring, and fixed at the correct distance by natural coloured aluminium pieces, and be so constructed as to have a free air flow of not less than 52%.

Roll-up Wooden Grille:

Shall be constructed from wooden profiled slats placed crossways (12 x 24.5mm), with 13mm space between. The slats shall be interconnected by a galvanized steel spring, and fixed at the correct distance by natural coloured aluminium pieces, and be so constructed as to have a free air flow of not less than 51%.

The grille shall be supplied to the specified finish and colour. Where a lacquered colour is specified for the aluminium grilles, it shall be lacquered in a scratch resistant epoxy- polyester powder, sprayed electro statically, and baked to 200°C. The colour shall be UV resistant due to ASTM G53.

The frame shall be of sufficient quality to be provided with the manufacturer's 10 year guarantee.

Note:

Each measured trench duct supplied, shall come complete with factory pressure tested heat exchanger, grille, frame and height adjusters, ready to install.